

WATER QUALITY MONITORING AND ASSESSMENT

Dr. C. K. Jain
Scientist- F, NIH, Roorkee

**Training Course on
HYDROLOGICAL INVESTIGATION TECHNIQUES FOR
WATER RESOURCES DEVELOPMENT & MANAGEMENT
(26-28 August 2012)**

WATER QUALITY MONITORING AND ASSESSMENT

Dr. C. K. Jain
Scientist 'F'

National Institute of Hydrology, Roorkee
E-mail: ckj_1959@yahoo.co.in

INTRODUCTION

The term 'water quality' is a widely used expression, which has an extremely broad spectrum of meanings. Each individual has vested interests in water for his particular use. The term water quality therefore, must be considered relative to the proposed use of water. From the user's point of view, the term 'water quality' is defined as physical, chemical and biological characteristics of water by which the user evaluates the acceptability of water. For example for the sake of man's health, we require that his water supply be pure, wholesome and potable.

WATER QUALITY MONITORING

Water quality problems stem basically from two factors, the natural hydrology of a river basin and the development and use of land and water resources by human beings. Depending on the interrelation of these two factors, a wide variety of quality problems can result. Each river basin, therefore, is unique and it must be subjected to individual and intensive water quality assessment to provide a proper basis for judicious management of the land and water resources.

For a proper planning of water quality monitoring programme, the following points should be considered:

- What are the objectives of the programme?
- From where samples are to be taken?
- Which determinants are of interest?
- When and how often samples are to be taken?
- What is to be done with the results?

These questions will provide a framework for defining measurement programmes. Results obtained from such a programme should be regularly reviewed to decide if any changes (e.g. determinants or sampling frequency) in the monitoring programme are necessary.

Objectives of the Monitoring Programme

It is an obvious point that the objectives of a programme should be clearly and precisely formulated by the user. If it is not done, inappropriate analytical data may well be provided and/or the user is likely to call for needlessly large or unduly small numbers of results. Furthermore, if the objectives are not precisely expressed, it will be difficult or impossible to decide the extent to which they are achieved.

It is suggested that analytical information should be requested on a regular basis only when the user knows beforehand that the results will be used-in a precisely known fashion-to answer one or more defined questions on quality. Requests for analysis based on the thought that the results may be ultimately prove to be useful should be avoided, particularly when-as is

increasingly the case - analytical sampling effort is limited. There is an almost infinite number of analysis that might be useful in most situations, but it is completely impracticable to attempt any such comprehensive coverage. Therefore, selection from all the possible objectives and determinants is essential for a proper planning of monitoring programme.

As a further means of optimising measurement programmes, the user should formulate his information needs as quantitatively as possible. As an extreme and perhaps rather artificial example of a badly defined requirement, consider the statement, 'to obtain information on the quality of river'. Such a statement is almost completely useless as a basis for the design of a monitoring programme for the following reasons:

- i. The determinants are not specified so that analysis required are not known;
- ii. The particular river and the locations on the river are not defined so that inappropriate sampling positions may be chosen;
- iii. No indication is given on the time scale or sampling frequency so that too few or too many samples may be collected and analysed;
- iv. As a result of all of the above lacks, there is no indication of the amount of data that will need to be processed and the nature of the data treatment so that appropriate data handling techniques cannot be defined.

Therefore, users of analytical results must seek to avoid uncertainties such as those in the above example by careful and quantitative definition of every aspect of their requirements. Thus, an objective such as the above would be better expressed by a statement of the form - 'to estimate each year the annual average concentration of ammonia ($\text{NH}_3 + \text{NH}_4$) at all river sites used for the production of potable water'. Appropriate statement of this type for other determinants of interest then provide a set of quantitative targets essential in optimising the choice of sampling, analytical and data handling techniques.

Objectives of GEMS/WATER

The fundamental objectives of the water quality monitoring system within the GEMS/WATER programme are to:

1. Assess the impacts of man's activities upon the quality of the water and its suitability for required uses.
2. Determine the quality of water, in its natural state, which might be available to meet future needs.
3. Keep under observation the source and pathways of specified hazardous substances.
4. Determine the trend of water quality at representative stations.

The first objective is met by the establishment of impact stations, the second by baseline stations, the third by either impact or baseline stations depending upon whether the hazardous substance is of artificial or natural origin, the fourth by trend stations.

Baseline stations are located in an area where no direct diffuse or point sources of pollutants are likely to be found. They are used to establish the natural background level of variables, to check if no synthetic compounds are found in remote areas (e.g., DDT) to assess the long term trends of surface water quality resulting from global atmospheric pollution. Impact stations are situated in water bodies where there is at least one major use of the water, or which

are greatly affected by man's activities. Four type of impact stations can be identified according to different uses of water:

- i. Drinking water - at the raw water intake before treatment for drinking water.
- ii. Irrigation - at the water intake before distribution for irrigation.
- iii. Aquatic life - river and lake stations representative of the general quality of the water body.
- iv. Multiple impacts - several water uses at the station and/or of the water body.

Trend stations are set up specially to assess the trends of water quality. They must be representative of a large area with various types of human activities. These stations should be more frequently sampled in order to increase the statistical significance of the average concentrations and to validate the trends.

Sampling Locations and Points

Sampling location and point mean the general position within a water body and the exact position at a sampling location at which samples are obtained. The objectives of a programme sometimes immediately define the sampling locations. For example, when the concern is to measure the efficiency of a chemical plant for purifying water, sampling locations will be required before and after the plant. Similarly, when the effect of an effluent discharge on the water-quality of a receiving river is of interest, samples will be required from locations upstream and downstream of the discharge. For larger scale water bodies (e.g., a river basin, a large estuary, a large urban drinking water distribution system), however, the objectives may be defined in terms that provide essentially no indication of sampling locations. For example, objectives such as 'to measure river quality within a river basin' or 'to measure the quality of water in a distribution system' give no indication of which of the virtually number of possible sampling locations are of interest. Such broadly expressed objectives are completely inadequate as a basis for the detailed planning of efficient programmes of sampling, and should always be sharpened so that they do indicate the position of sampling locations. A commonly useful device for helping in this respect is to consider the intended use of the water since this will aid in indicating these positions in a water body where quality is of key importance.

Fig. 1 illustrates the hypothetical case of river system along with the criteria for the choice of the different sampling sites. Fig. 2 and 3 illustrates similarly the location of sampling sites for lakes and ground water with corresponding criteria for the choice of different sampling sites.

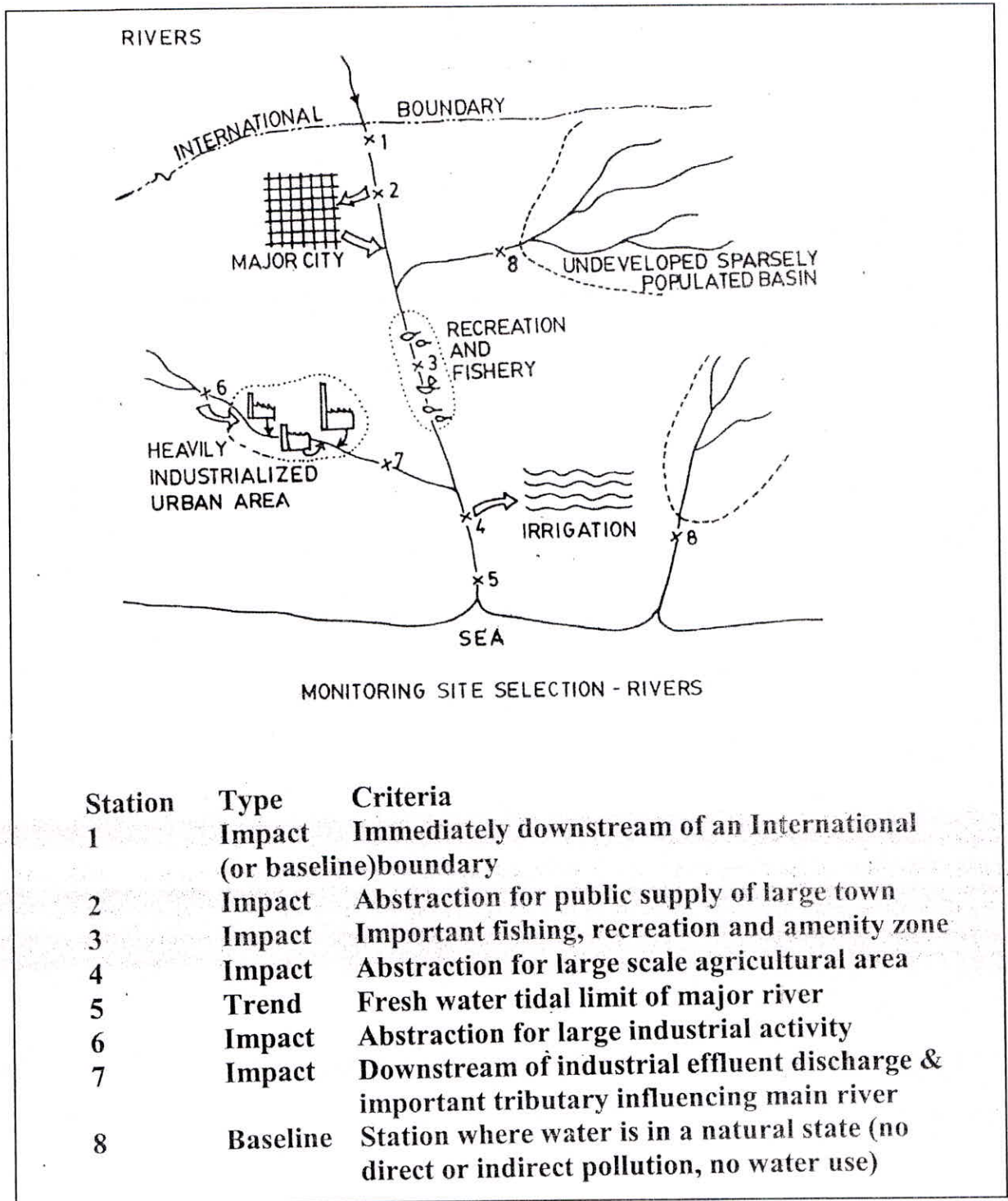

Figure 1. Monitoring Site Selection - Rivers

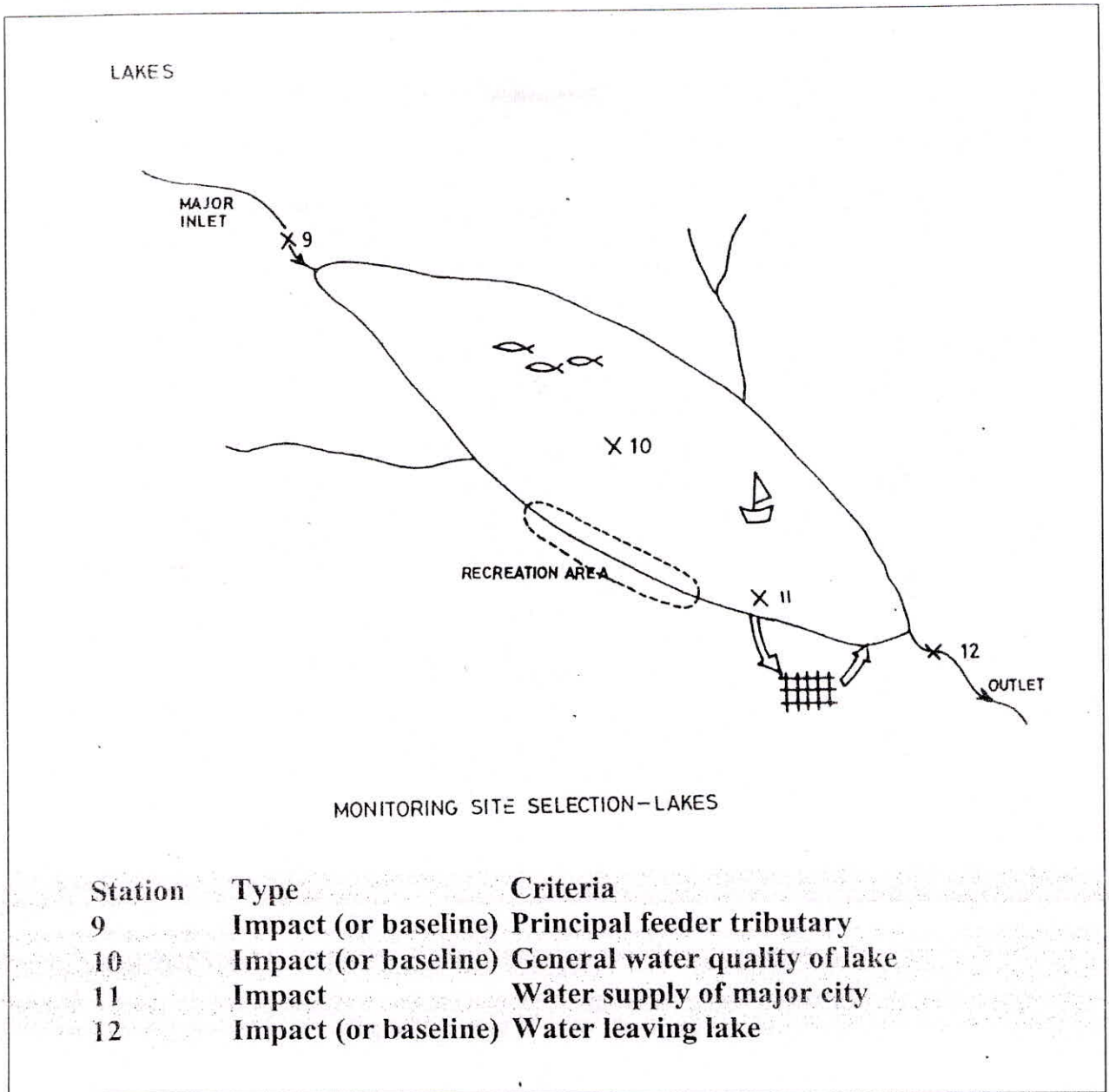
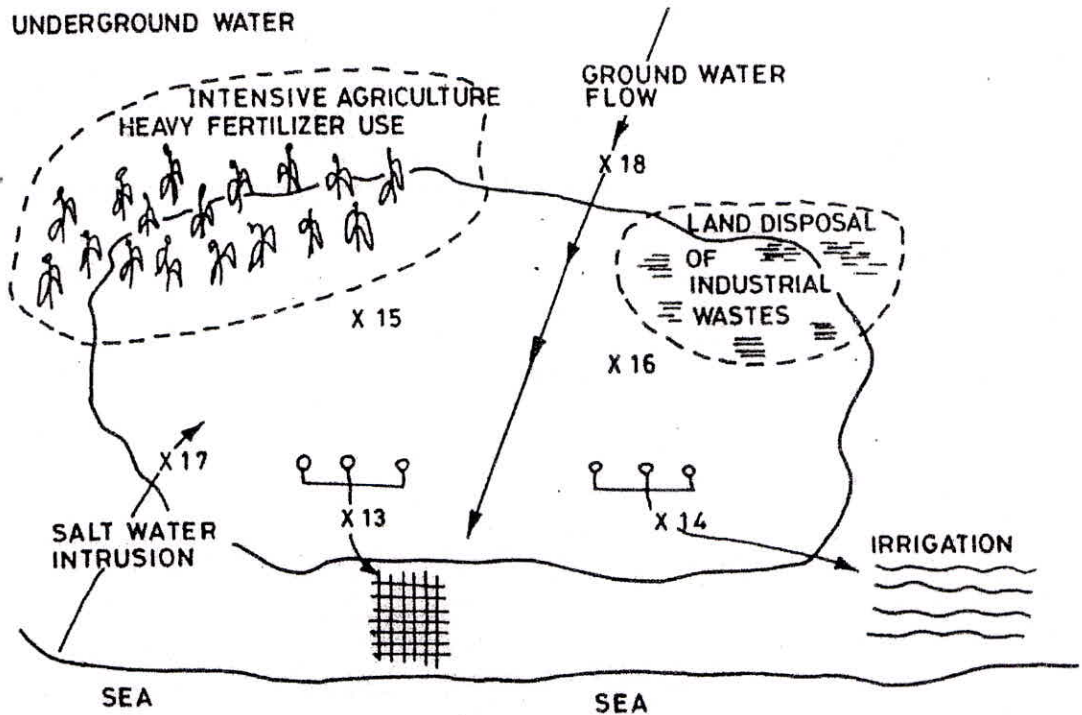

Figure 2. Monitoring Site Selection - Lakes



MONITORING SITE SELECTION - UNDERGROUND WATER

Station	Type	Criteria
13	Impact	Water supply to large town threatened by fertilizer residues and saline intrusion
14	Impact	Water for large scale irrigation threatened by leachate from waste tips
15 } 16 } 17 }	Impact	Water supply of major city
18	Baseline	No human activities in the ground water recharge area

Figure 3. Monitoring Site Selection – Ground Water

Determinants of Interest

The particular determinants appropriate to a programme are critically dependent on the type of water and the objectives of the study. Depending on the intended use of a receiving water, the parameters listed in Table 1 are of significance for water quality characterization. These serve as guidelines for analysis of wastewater quality for purpose of treatment and control. The parameters listed in Table 2 are frequently used for the identification of various types of pollution associated with industrial waste water.

Some of the most important and most frequently used tests in the analysis of water are the non-specific tests listed in Table 3. These tests often measure a property of a group of substances. For example alkalinity indicates the capacity of water to neutralize hydrogen ions. Many of these tests are used to determine the suitability of natural water for industrial or municipal use and to determine the type and degree of treatment required. Table 4 lists some of the more frequently measured parameters in pollution studies.

Table 1. Parameters for Water Quality Characterization

Water Use	Quality Parameters
Domestic water supply	Colour, odour, taste Organic content: Chlorine demand, COD, BOD, TOC, phenols Carcinogens and toxic compounds: Insecticides, pesticides, detergents Turbidity, salinity Alkalinity, pH Total hardness, Ca, Mg, Fe, Si, etc Pathogenic organisms, total bacterial count (37°C), E. Coli, plankton count.
Fish, shellfish, wildlife and recreation	Colour, odour Toxic compounds Turbidity, floating matter, sludge deposits, salinity Temperature Dissolved Oxygen, BOD Alkalinity, pH, Pathogenic organisms, plankton count nitrogen, phosphorous, etc. (inorganic nutrients which support algae blooms and other undesirable aquatic growth).
Agricultural irrigation	Salinity and Na-Ca content Alkalinity, pH Pesticides, growth regulators Persistent synthetic chemicals (e.g., polyethylene derivatives, asphalt sprays, etc.) Pathogenic organisms.
Watering of livestock	Salinity Toxic compounds Pathogenic organisms Plankton count.

Table 2. Significance of Parametric Measurements

Test(s)	Significance
Dissolved solids	Soluble salts may affect aquatic life or future use of water for domestic or agricultural purposes
Ammonia, nitrites,	Degree of stabilization (oxidation) or nitrates, and total organic nitrogenous matter, organic nitrogen
Metals	Toxic pollution
Cyanide	Toxic pollution
Phenols	Toxic pollution, odor, taste
Sulfides	Toxic pollution, odor
Sulphates	May affect corrosion of concrete, possible biochemical reduction to sulfides
Calcium and magnesium	Hardness
Synthetic detergents	Toxic pollution

Table 3. Nonspecific Water Quality Parameters

Physical	Chemical	Physiological
Filterable residues	Hardness	Taste
Salinity	Alkalinity and acidity	Odor
Density	BOD	Color
Electrical conductance	COD	Suspended solids
	Total Carbon	Turbidity
	Chlorine Demand	

Table 4. Tests used for the Measurement of Pollution of Natural Waters

Nutrient Demand	Specific Nutrients	Nuisance	Toxicity
DO	Nitrogen:	Sulfide	Cyanide
BOD		Sulfite	Heavy Metals
COD	Ammonia	Oil and Grease	Pesticides
Total Carbon	Nitrate	Detergents	
	Nitrite	Phenols	
	Organic nitrogen		
	Phosphorous:		
	Orthophosphate		
	Polyphosphate		
	Organic phosphorous		

Frequency and Time of Sampling

The quality of water in various water bodies is rarely if ever constant in time but is subject to change. While there may be some relationship between the role of change of different variables others alter independently. In measuring the mean, maximum and minimum values of variables over a period of time the closeness of the monitored values to the true values will depend upon the variability of the variables and the number of samples taken. The larger the number of samples from which the mean is derived the narrower will be the limits of the probable difference between the observed and true means. These confidence limits are not

directly proportional to the number of samples but to the square of the number. Therefore, in order to double the reliability of a mean value the number of samples must be increased to four fold.

Variations in water quality are caused by changes (increase or decrease) in the quantity of any of the inputs to a water body system. Such changes may be natural or man-made and either cyclic or random. Water quality variation may therefore be similarly cyclic or random.

The variability differs between rivers, lakes and underground waters. It is most pronounced in rivers and the ranges will be greater, the nearer the sampling point is to the source or sources of variability. As the distance from the source increases longitudinal mixing smooths out irregularities and fewer samples are needed to meet given confidence limits. However, as the distance between the source of variability and the sampling point increases not only will there be reduction in the range of variation but there will also be dilution and some variables will be reduced by self purification, deposition and adsorption. These effects must be considered if a sampling station used for quality control purposes is located some distance from the area of point of use.

In lakes the mass of water and good lateral mixing provide an inertia against any rapid changes resulting from modifications in inputs and outputs. Many lakes exhibit marked seasonal variations due to thermal stratification, overturn and biological activity. Depending upon the type of lake the sampling may be carried out with a seasonal bias related to the natural cycles of the lake.

Underground water has a lower variability than that of either rivers or lakes. The rate of quality changes depends upon the depth of sampling, water volume of the aquifer and the hydraulic conductivity. The time elapsing between changes in land use and in surface recharge water and their effect upon the underground water will depend upon the time of percolation. Variations are often, but not invariably, seasonal with a time lag according to the rate of percolation. Direct injection into boreholes or saline intrusion from subterranean sources may take effect more rapidly.

The time of sampling is also of main concern when the quality of the water shows more or less regular variations, e.g., diurnal variations in the concentration of dissolved oxygen in rivers and variations of quality on start-up and shut-down of industrial plant.

It is seldom if ever that the quality of water at only one instant of time is of interest. Normally, information is required for a time period during which quality may vary. The basic problem arises, therefore, of deciding the time at which to collect samples so that they will adequately represent the quality during the period of interest.

The best technical solution to this problem would often be to use an automatic, on-line instrument providing continuous analysis of the water of interest. This approach can be of great value in that, in principle, a continuous record of quality is obtained and the problems of selecting particular times for sampling do not arise.

SAMPLING TECHNIQUES

Sampling is the first of a series of steps leading to the generation of water quality data and is an exceedingly important one. Care must always be taken to ensure obtaining a sample

that is truly representative. Further, the integrity of the sample must be maintained from the time of collection to the time of analysis. If the sample is not representative of the system sampled or if the sample has changed in chemical composition between sampling and analysis, all care taken to provide an accurate analysis will be lost.

Sample Containers

Chemically neutral plastic (polyethylene) or glass containers should be used, non-breakable plastic containers being more desirable than glass. However, when sampling for phosphorous, pesticides and other similar type compounds, glass containers must be used because of their possible interference with plastic. When the sample is collected for analysis of metals, the sampler should be designed so that no metallic parts come into contact with the sample.

Sampling from Surface Water

Water samples for physical, chemical and biological analysis is taken in the same manner. For bacteriological analysis it is always necessary to use sterilized equipment and apparatus. One to two litres of sample is normally sufficient for most physical, chemical and bacteriological parameters. Before the sampling bottles are filled, they should be rinsed two to three times with the water to be sampled. Depending upon desired accuracy of the sample and local conditions, different type of sampling devices can be used.

Manual sampling: The simplest form of water sampling device is a bottle attached to a string. To lower a plastic or glass into a body of water it is necessary to use a bracket or holder of sufficient weight to overcome the buoyancy of the bottle and allow it to sink as rapidly as desired (Fig. 4). In this case, even if the bottle is lowered rapidly to the desired depth, a certain amount of water from the overlying layers will be included in the sample.

When water from a particular depth is to be collected, Meyer's sampler bottle (Fig. 5) or Dussart sampler (Fig. 6) may be used. In both of these devices, a closed container is lowered to the desired depth and then by means of a jerk of the suspending cord, the container is opened. In these samples, when the bottle is full it cannot be stoppered and must be pulled up in an open position. Thus, to some extent, admixtures with other layers of water cannot be avoided.

For greater accuracy and for water depths greater than 50 m, special samplers such as Kemmerer (Fig. 7) may be used. This essentially consists of bottles, opened at both ends, which are lowered to desired depth in the open position in order to allow water to stream through the bottle. Closure is affected by a drop weight or a messenger, which slides the supporting wire or cord.

Automatic sampling: Automatic sampling devices are used to collect composite samples over extended periods of time. Several types of automatic samplers are available in the market, such as vacuum type, pressure type and those which are operated by pumps. Automatic samplers are programmed by timing devices designed to collect small aliquots of samples at regular intervals during a prescribed period of time. These aliquots are either stored in separate containers in the sampling device or discharged into a common container thereby producing a composite sample. Automatic sampling devices are widely used for sampling waste discharges from municipal and industrial waste water treatment plants.

Sampling from shallow water: In shallow waters a simple glass tube may be used for sampling. For example, an integrated sample may be collected by immersing a tube, open at both ends. A sample from a particular depth may be collected by immersing a tube with both top and bottom closed. The top is then opened after the lower end has reached the desired depth. When the sample has been collected the top is closed again and the tube is withdrawn.

Sediment Sampling from Surface Water

Sediments are collected for performing chemical and biological analysis. There are several types of dredgers available for sampling sediments. Of these, the Eckman, Petersen and Surber dredges are used commonly for rivers and lakes.

Eckman dredge (Fig. 8) is a fairly light, spring-triggered, brass dredge made in several sizes (about 15x15 cm, 24x24 cm and 30x30 cm, of which the 15x15 cm size is most common). After reaching the bottom, a messenger is sent down the line to trigger closure of the jaws and enclose a sample of bottom sediment.

The Petersen dredge (Fig. 9) is made of steel and is quite heavier. This is not spring equipped, requires no messenger and its closing is induced by the release of tension in the line once the dredge has settled on the bottom. The dredge is quite heavier (30 kg or more) and require the use of a small winch or boat crane and has to be lowered carefully so as not to produce a shock wave ahead of the dredge as it reaches the bottom sediments. The heavier dredges collect samples from sediments, which are too hard for an Eckman dredge.

The Surber sampler (Fig. 10) is a light weight device for collecting biological samples in water depths up to 0.75 m for fast flowing streams. It consists of strong close-woven fabric approximately 70 cm long. This net is held open by a one square foot metal frame hinged at one side to another frame of equal size. In operation, the frame which supports the net is in a vertical position while the other frame is locked into horizontal position against the other bottom deposits and are dug to a depth of at least 6 cm. The dissolved organisms then drift into the open net. In shallow water, semi-quantitative bottom samples may be obtained by bringing the bottom sediment into suspension by kicking the bed one or more times and collecting the dislodged organisms in a net.

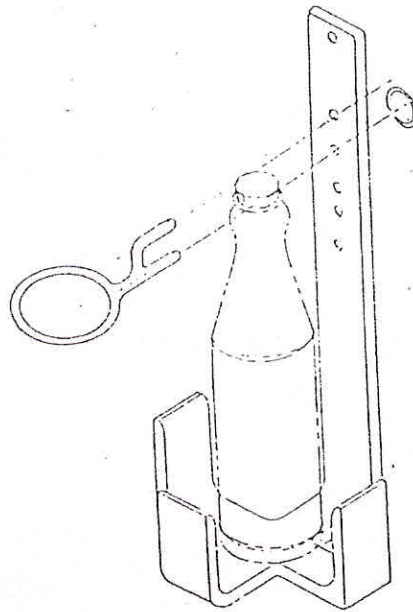

Figure 4. Sample Bottle Holder for Manual Sampling

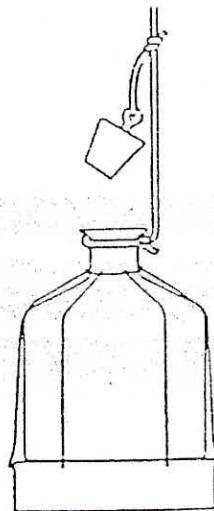
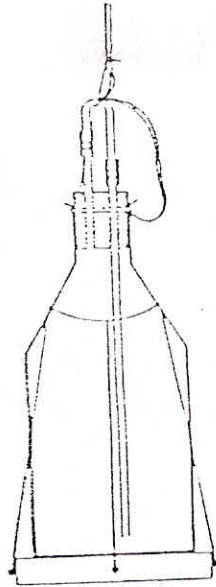

Figure 5. Meyer's Sampling Bottle



Figur 6. Dussart Sampler

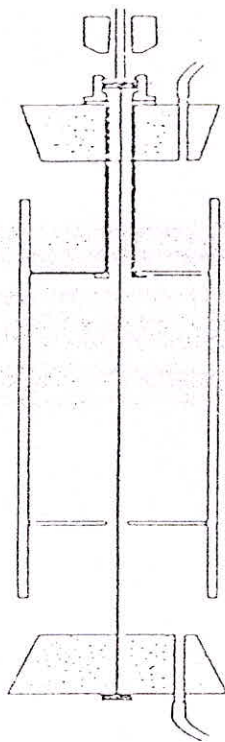

Figure 7. Kemmerer Sampler

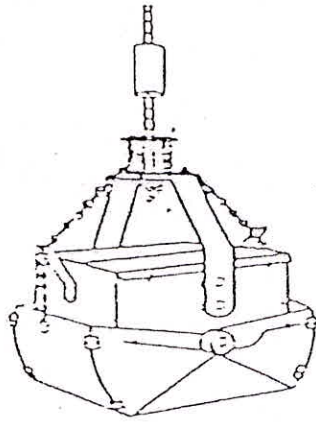

Figure 8. Eckman Dredge

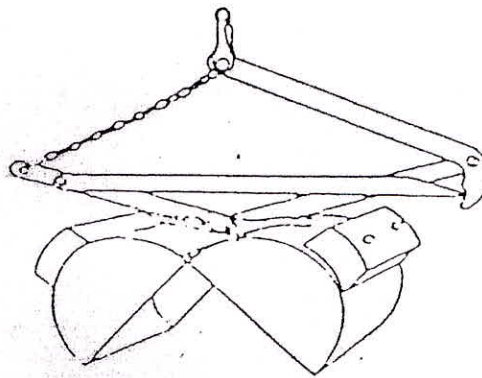

Figure 9. Petersen Dredge

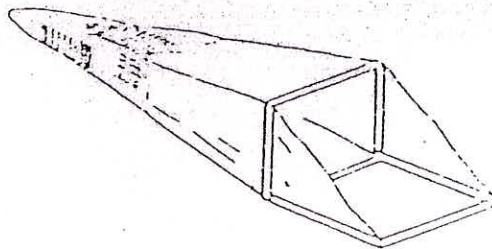

Figure 10. Surber Sampler

Ground Water Sampling

Ground water sample collection involves sampling of drainage water, open well water and drilled well water.

The drainage water may be collected directly from the drainage outlet in the sample bottle. When open well water is to be collected, it should be pumped for about 5 min before the collection takes place/ If the well is only slightly used, water should be pumped for 20 min and longer, until a constant temperature or conductivity of the water is reached. The pumped water should be drained out of the well perimeter to prevent the infiltration of washed water back into the well.

Samples from drilled wells in which water is standing for a long time or where the upper opening is not adequately closed, should be collected only after the well has been pumped for a sufficient time to ensure that the sample represent the ground water which feeds the well. It is often necessary to collect a water sample from a particular depth without mixing it with water from other layers.

WATER ANALYSIS

Water Quality Parameters

The parameters which characterize water quality may be classified in terms of the kinds of measurements, viz. physical properties (e.g. temperature, electrical conductivity, colour, turbidity), inorganic chemical components (e.g. dissolved oxygen, chloride, alkalinity, fluoride, phosphorous, nitrogen, metals), organic chemicals (e.g. phenols, chlorinated hydrocarbons, polycyclic aromatic hydrocarbons and pesticides), and biological components, both microbiological such as faecal coliforms, and macrobiotic, such as worms, plankton and fish, which can indicate the ecological health of the aquatic environment.

Field Analysis

Because of chemical changes that occur in water samples during transit and storage, certain parameters should be measured on-site immediately after the sample is taken. These are temperature, pH, dissolved oxygen and electrical conductance. These measurements are usually carried out using portable test kits.

Temperature may be measured on-sit with a standard laboratory thermometer. Thermometers contained in metal protective casings are available commercially for field work and are calibrated in scales suitable for normal water temperatures.

The pH value of water may be determined potentiometrically by a wide variety of pH meters equipped with glass and reference electrode. Each pH meter requires standardization with standard buffer solutions before each measurement.

Electrical conductance is a measure of dissolved solid concentrations. This is usually measured in the field by Wheatstone bridge type instrument with a conductivity cell, which is immersed in the water sample or directly in the water body for measurement of electrical conductivity.

Dissolved oxygen can be measured either by well known Winkler method or by electrometric method. The electrometric method is more rapid and more versatile than the Winkler procedure because of its capability for direct measurement of dissolved oxygen.

Preservation Techniques

In addition to on-site measurements discussed in previous section, colour, turbidity, nitrogen, phosphorous, silica, residue and other parameters should be determined within hours of sampling. These analysis are best carried out in a mobile laboratory. It is also desirable, though not essential, to measure acidity, alkalinity, total hardness, calcium and magnesium within hours after taking the sample(s). Some laboratories, however, measure these in a permanent laboratory within seven days of sample collection.

Once samples have been collected and treated as required, sample bottles should be tightly capped and forwarded to a laboratory for analysis in accordance with standard methods. The following are some of the guidelines on the handling and preparation of samples.

Colour: In natural waters, colour is due to mainly humic acid and organic matter leached from decaying vegetation, including tannin and vegetable dyes. Iron and manganese compounds also impart colour to natural waters. Sewage and industrial waters cause serious colour problems in local areas.

Turbidity: Turbidity is largely a value reflecting the particle size of suspended matter and is not a measure of the amount of material. Turbidity may be due in part or in total to suspended clay, silt, bacterial decomposition products, iron oxide, finely divided organic matter, microscopic organisms, and industrial and mining substances. Turbidity affects all uses of water and adds to the cost of water treatment for these uses. Turbidity should be measured as quickly as possible.

Residue: As par of the laboratory measurement technique, the sample is filtered through a standard glass fibre filter. The filterable residue is the material remaining in the dish after evaporating the filtrate to dryness at 105⁰C to achieve a constant weight. The fixed filterable residue is the material remaining in the same dish after the filterable residue has been subjected to heat for 1 hour at 550⁰C. The nonfilterable residue is the material retained on the glass fibre filter after drying to constant weight at 105⁰C. The fixed nonfilterable residue is the material remaining on the same glass fibre filter after subjecting the nonfilterable residue to heat for 1 hour at 550⁰C.

Acidity: Sample should be collected in polyethylene bottles and stored at a low temperature and analysed as soon as possible after sampling. In the laboratory an electrometric titration method may be used where a sample aliquot is titrated with standard alkali such as NaOH to designated end points, usually pH 4.5 and pH 8.3.

Alkalinity: Alkalinity is a measure of the bicarbonate, carbonate and hydroxide ions. In most natural waters, the principal anion is bicarbonate with carbonate and/or hydroxyl ion being present only if the pH is greater than 8.3 (phenolphthalein alkalinity). Phenolphthalein alkalinity is usually due to carbonates and/or free hydroxides present in treated waters or waste waters. Most surface waters show no phenolphthalein alkalinity, since all alkalinity is

due to the bicarbonates of alkali earth. Alkalinity may be determined by using sulphuric acid or by a potentiometric method.

Total Hardness: Hardness of water is the property attributed to the presence of alkaline earths. Calcium and magnesium are the principal alkaline earths in natural waters. Hardness of water presents one of the greatest problem in the use of water contributing to dense scale formation on heating surfaces in boilers, cooling water equipment and industrial process systems. Total hardness may be determined by the standard titration method using the sodium salt of EDTA and Eriochrome black T as indicator.

Nitrogen: Nitrogen is an essential constituent of all living organisms. It occurs in various oxidation states ranging from N^{-3} (ammonia and amino group) to N^{5+} (nitrate). Most lake water analysis are restricted to ammonia, nitrate, nitrite and Kjeldahl nitrogen (ammonia nitrogen plus organic nitrogen). Sample should be preserved with 0.8 ml concentrated sulphuric acid per litre of sample. Then the sample should be stored at 4°C .

Oxygen: Sample collected for oxygen determination should be collected in narrow mouthed, BOD bottle. Other bottles may also be used but special care must be taken to avoid contamination with atmospheric oxygen. The sample should be immediately analysed by the Winkler titration method or by a dissolved oxygen meter using a membrane electrode.

The BOD test empirically measure the quantity of oxygen required for the biological oxidation of water-borne substances under specific test condition. It is generally based on a five day incubation method at 20°C which should be started immediately in the field, preferably within four hours after the sample has been taken. The composition of the dissolved oxygen content at the beginning and end of the incubation period provides a measure of the biochemical oxygen demand. The oxygen consumed is a measure of the oxidizable material in waters.

Chemical oxygen demand (COD) is the measure of oxygen equivalent of most organic matter in water. COD requires as complete an oxidation as possible with a very strong oxidant mixture such as potassium dichromate and sulphuric acid. If there is any delay before analysis for COD, the samples may be preserved by acidifying with sulphuric acid.

Carbon: Samples collected for organic carbon determination should be refrigerated and kept tightly capped. Sample may be preserved by adding 1 ml concentrated sulphuric acid per litre of sample. In laboratory a combustion method using an infra-red carbon analyser would be suitable to determine the total organic carbon content.

Metals: Metals are usually measured under three different categories, depending upon the requirement and nature of the study. These are dissolved metals, suspended metals and total metals. Sample collected for dissolved metals should be filtered at the time of collection through a $0.45\ \mu\text{m}$ membrane filter and the sample acidified with 2 ml concentrated nitric acid per litre after filtration. Samples collected for suspended metals should be filtered at the time of collection through a $0.45\ \mu\text{m}$ membrane filter and analysis carried out on the portion of the sample retained on the filter. Total metal determination may be performed by calculating the sum of dissolved and suspended metal concentrations. Total metal may also be determined by conducting an analysis on an unfiltered sample, treated with nitric acid so as to dissolve all metals. Trace elements are treated with 2 ml concentrated nitric acid per litre of sample, to preserve the sample against changes in transportation and storage. Samples

thus preserved can be stored for a period of six months. The summary of analytical methods used for some common parameters is given in Table 5.

Table 5. Summary of Analytical Methods

Parameter	Analytical method	Equipment used
pH	Electrometric	pH meter
Conductivity	Wheatstone bridge	Conductivity meter
Temperature	Thermometric	Thermometer
Turbidity	Photometric	Turbidity meter
Solids	Gravimetric	-
Acidity	Titrimetric	-
Alkalinity	Titrimetric	-
Hardness	Titrimetric	-
DO	Iodometric	-
BOD	Dilution	BOD Incubator
COD	Dichromate	COD Digestion System
Calcium	Titrimetric	-
Magnesium	Titrimetric	-
Chloride	Mercuric nitrate	-
Sulphate	Turbidimetric	Turbidity meter
Phosphate	Ascorbic acid	Spectrophotometer
Ammonia-nitrogen	Ion-selective electrode	Ion-analyser
Nitrate-nitrogen	Ion-selective electrode	Ion-Analyser
Nitrite-nitrogen	Ion-selective electrode	Ion-Analyser
Sodium	Flame-emission	Flame photometer
Potassium	Flame-emission	Flame photometer
Trace elements	Atomic absorption	AAS
Pesticides	Gas chromatography	GC with ECD and NPD

Laboratory for Testing

Basic layout planning is an exercise of packing laboratory benches in the most economical manner into a minimum space. The traditional method is to place benches around the walls and then, if more space is available, more benches may be placed in the middle of the room. The following items should be acquired in developing a basic water quality laboratory:

- Adequate space with essential services provided;
- Distilling apparatus and adequate supply of volumetric and other laboratory glassware;
- Supply of standard chemicals and reagents for the parameters to be measured;
- Analytical balance;
- Portable equipment like pH meter, conductivity meter, turbidity meter, water testing kit;
- UV-Visible spectrophotometer;
- General purpose equipment like oven, furnace, hot plate, autoclave, BOD incubator, bacteriological incubator;
- Bacteriological equipment.

As the requirement for more data develops and the need to measure constituents at low concentrations increases, consideration should be given to procuring more sophisticated instrumentation such as:

- Atomic absorption spectrophotometer;
- Deionizing equipment to purify distilled water for trace element analysis;
- Chromatographic equipment;
- Infra-red (IR) spectrophotometer;
- Auto analyzers
- Radioactivity measuring equipment

Because of the wide use and versatility of atomic absorption units, these may even be considered as a requirement for a basic laboratory. These units are relatively expensive but add materially to the efficiency of a laboratory operation.

Scientific instruments and equipment must be thoroughly checked and evaluated before final acquisition. A very important consideration in the procurement of equipment is the availability of service and spare parts. In the development of laboratory facilities it is important to keep provision for expansion as needs arise and to keep abreast of the latest developments in this field.